

iSP
Technologies

ACTIVE
SERIES



LT2 SERIES
ACTIVE 3 WAY SPEAKER SYSTEM
OWNERS MANUAL

IMPORTANT SAFETY INFORMATION!

Please read this very carefully before operating this unit.

- Read **ALL** instructions carefully before using this unit.
- Do not operate this unit near water, in the rain or where there is moisture. If this warning is ignored a serious electrical shock or death may occur.
- Do not attempt to service this unit. No user serviceable parts inside. Refer servicing to qualified, ISP approved service personnel.
- Never remove or defeat the ground connection on the power cord of this unit.
- Care should be taken to avoid spilling any foreign objects or liquid into this unit.
- This active speaker system has three internal power amplifiers and an external heatsink located on the back of the speaker for cooling of the internal amplifiers. Care should be taken to avoid placing this active speaker in a location where the external heatsink does not allow proper cooling of the internal amplifiers. Avoid placing this system close to other heat sources. The external heatsink may reach high temperatures under normal use. Do not block the external heatsink with any other object. Make certain there is proper ventilation for the external heatsink when is use.
- Do not drive the LT2 into excessive heavy distortion for an extended period of time to avoid premature speaker failure.
- Failure to follow these instructions may void the warranty.



Caution: Exposure to extremely high noise levels can cause permanent hearing loss.

The LT2, LT2S, and LT2XF speaker system is capable of producing in excess of 129db SPL at 1 meter. Continued exposure to noise levels in excess of 90db may cause permanent hearing loss. Below is a chart of the OSHA (Occupational Safety & Health Administration) regulations for Occupational Noise Exposure. Please note: OSHA requires hearing protection for any work environment when the sound levels exceed those shown in Table G-16 when measured on the A scale of a standard sound level meter at slow response.

TABLE G-16- PERMISSIBLE NOISE EXPOSURES	
Duration per day, hours	Sound level dBA slow response
8	90
6	92
4	95
3	97
2	100
1 1/2	102
1	105
1/2	110
1/4	115

INTRODUCTION

Thank you for purchasing ISP Technologies LT2 active speaker system. The LT2 is a high output three-way active speaker system designed to deliver HI-FI sound quality for high SPL sound reinforcement applications. The LT2 is designed with a 400-watt 15-inch woofer, a 300-watt 8-inch midrange driver and a high performance, 2-inch high frequency compression driver. The LT2 has three separate power amplifiers capable of producing upwards of 900 watts of power. Each amplifier receives its input signal from an internal fourth order crossover network specifically designed to provide optimized phase and frequency response at each crossover point. The internal amplifiers are based on ISP Technologies patent pending D-CAT (Dynamic Current Amplifier Technology) amplifier technology. The D-CAT technology is capable of delivering extremely high output current providing an improvement in transient response, output current, and a noticeable improvement in *PUNCH*. The D-CAT amplifier technology utilizes a monolithic power amplifier driver that reduces parts count and greatly improves reliability. The D-CAT amplifiers provide improved reliability by including short circuit and over temperature protection.

The LT2 offers both ¼ inch RTS and XLR balanced inputs as well as, ¼-inch RTS and XLR outputs for connecting multiple speakers. A sensitivity adjustment knob allows you to adapt the speaker for a wide range of common signal levels. The Tripower cabinet is made of high quality 13 ply Baltic birch plywood with a durable spray on black finish for long life.

SUSPENDING LOUDSPEAKERS

Important Notice!!!

The information in this section has been gathered from engineering data and is for informational purposes only. None of the information in this section should be used without first obtaining competent advice with respect to applicability to a given circumstance. None of the information presented herein is intended as a representation of warranty on the part of ISP Technologies. Anyone making use of this information assumes all liability arising from such use.

All information presented in this manual is based upon materials and practices that are most common to The United States of America and may not directly apply to other countries because of differing material dimensions, specs, and/or local regulations. Users in outside countries should consult with appropriate engineering and regulatory authorities for specific guidelines.

Correct use of all flyware is required for secure system suspension. Careful calculations should always be performed to ensure that all components are used within their working load limits before the cabinet suspended. Never exceed the maximum load ratings.

Before hanging any speaker system, always inspect all components for cracks, deformations, corrosion, missing, loose or damaged parts that could reduce strength and safety of the cabinet. Do not suspend the cabinet until the proper corrective action has been taken.

ATTACHMENT TO STRUCTURES

A licensed professional engineer must approve the placement and method of attachment to the structure prior to the installation of any overhead object. The following performance standards should be provided to the professional engineer for design purposes; Uniform building code as applicable, Municipal Building code as applicable and Seismic Code as applicable.

INSPECTION and MAINTENANCE

Suspension systems are comprised of mechanical devices and, as such, they require regular inspection and routine maintenance to insure proper function ability. Any suspended ISP Technologies loudspeaker must be inspected for fatigue at least annually. The inspection shall include a visual survey of all corners and load bearing surfaces for signs of cracking, water damage, de-lamination, or any other condition that may decrease the strength of the loudspeaker enclosure.

Flyware that is provided with or for any ISP Technologies loudspeakers must be inspected for fatigue at least annually. The inspection shall include a visual survey of the material for signs of corrosion, bending, or any other condition that may decrease the strength of the fastener.

ISP Technologies is not responsible for the application of its products for any purpose or the misuse of this information for any purpose. ISP is also not responsible for the abuse of its products caused by avoiding compliance with inspection and maintenance procedures.

REAR PANEL DESCRIPTION

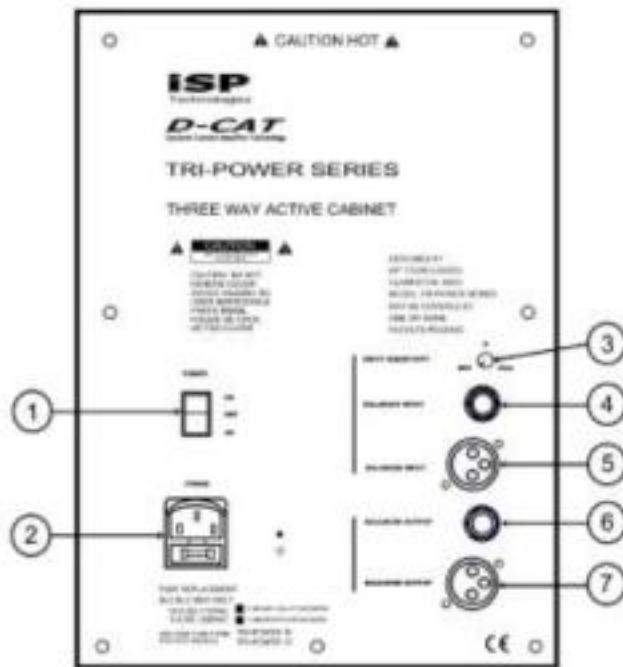

- 1. POWER SWITCH**-This switch provides power to the Tri-Power power amp section. This switch is a three-position switch where center is OFF and the outer positions are ON.
- 2. POWER INLET MODULE**-This module provides a connection for the power cord and also houses the mains fuse. (See Fuse Replacement Section)
- 3. INPUT GAIN**- This control determines the overall input level of the signal to the power amp section of the Tri-Power cabinet. Adjusting this level will not affect the level of the signal passing through to output connectors.
- 4. BALANCED 1/4" PHONE INPUT**-This jack provides an input for balanced or unbalanced line level signal source.
- 5. BALANCED XLR INPUT**-This female XLR connector provides an input for balanced line level signal source
- 6. BALANCED 1/4" PHONE OUTPUT** – This 1/4" phone provides a balanced loop through for connecting to additional powered cabinets.
- 7. BALANCED XLR OUTPUT**- This XLR male provides a balanced loop through for connecting to additional powered cabinets.

FUSE REPLACEMENT

1. Use a small screwdriver as shown to slide the fuse cover out from the power inlet module. The fuse can be found inside the fuse cover module after it is pulled out.

NOTE: A SMALL COMPARTMENT IS ALSO PROVIDED WITHIN THE FUSE COVER MODULE FOR STORING A SPARE FUSE.

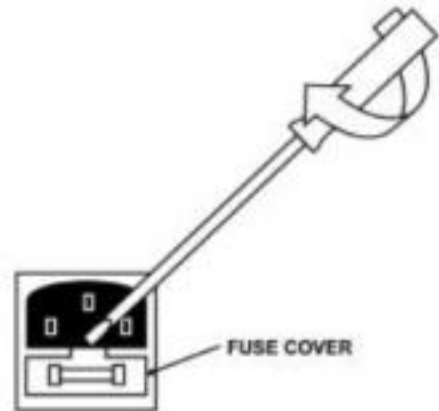

2. After replacing the fuse with another of identical specifications, push the fuse cover module fully back into place, ensuring that the fuse has snapped onto the fuse holder inside the power inlet module.

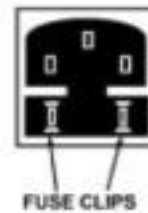

CONNECTION DIAGRAM

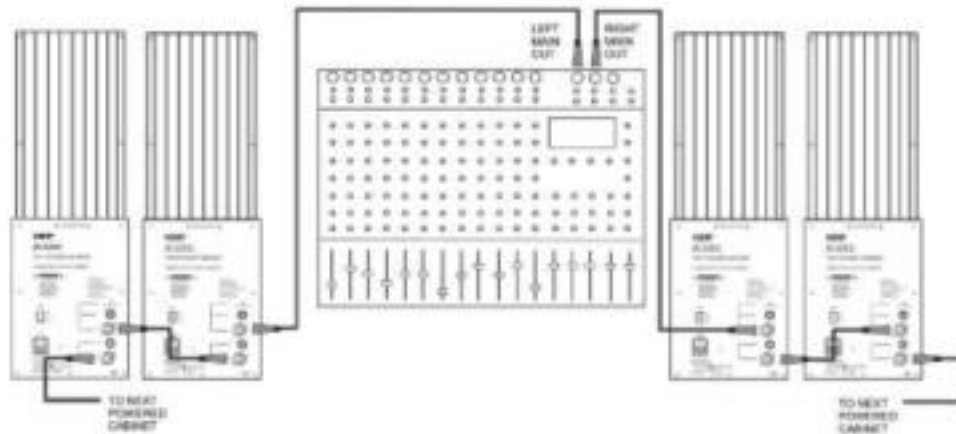

BALANCED CONNECTION DESCRIPTION

The ISP Tripower series has balanced XLR and 1/4" phone inputs and outputs configured to AES standards (Audio Engineering Society). These connections are connected in a loop through configuration and will accept a balanced line-level input. The standard phase configuration is that pin 2 is (+), pin 3 is (-), and pin 1 is shielded ground on the XLR. On the 1/4" phone jacks the configuration is Tip is (+), Ring is (-), and Sleeve is ground.

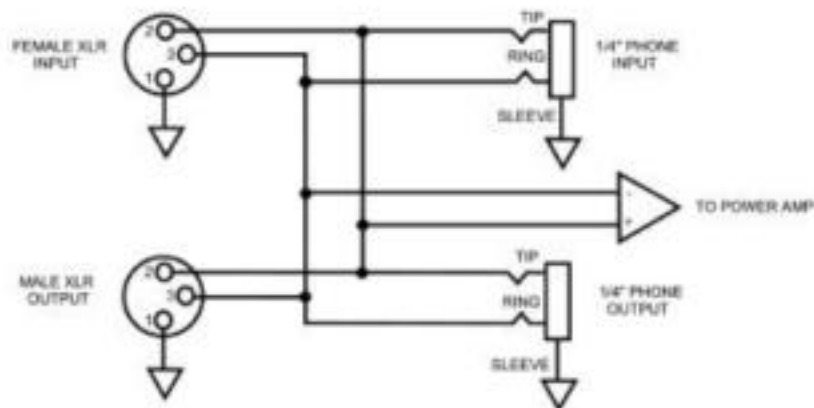

NOTE: IF AN UNBALANCED SIGNAL SOURCE IS USED, THE MALE XLR AND 1/4" PHONE OUTPUTS FOR LOOPING THROUGH TO ADDITIONAL POWERED CABINETS WILL ALSO BE UNBALANCED.

THERMAL CONDITIONS

The ISP LT2 Series is capable of producing in excess of 900 watts at full power. This generates heat that must be dissipated in order to maintain reliability and insure the amplifier components stay within their operating temperature specs. To accomplish this, the amplifier is mounted on a heatsink that is exposed on the rear of the cabinet. Airflow is forced through a bass port at the bottom of the fins of the rear heatsink via the air movement from the 15" speaker. It is recommended that the fins have at least 6 inches of clearance from any obstruction to allow proper ventilation to occur.

In addition, the amplifiers are thermally protected internally via a thermal switch, which will attenuate the signal 40db if the heatsink temperature exceeds a certain temperature. When the temperature drops below a certain point, full signal will be restored. Tests have shown under extreme conditions that cycling will occur approx. (40 sec. ON, 20 sec. OFF)

Under extreme conditions, such as when ambient temperatures are too high (hot rooms, extreme outdoor temperatures) it is recommended to use a fan on the fins to reduce the cycling effects.

It should also be noted that a separate internal thermal breaker also protects the power transformer. If the power transformer temperature reaches a critical point, the internal thermal breaker will open. The power LED on the front of the cabinet will go out and the LT2 will shut down for several minutes while the power transformer cools. If this condition occurs, simply reduce the signal level of the system. This will only occur if the LT2 is continually pushed into heavy distortion.

NOTE: The power transformer inside the LT2 contains an enamel coating on the wires. During the first several hours of heavy use, the LT2 may have a slight odor caused by the enamel on the transformer wires heating.

SPECIFICATIONS

System

Frequency Range	45 Hz – 20 KHz
Frequency Response (-3dB)	50 Hz – 19 KHz
Horizontal Coverage Angle	100 degrees.
Vertical Coverage Angle	65 degrees.
Peak Output @ 1m	129 dB
Crossover Points	350 Hz, 2.6 KHz
Input Type	Balanced differential
Input Impedance	10K ohms
Thermal Protection	Output Drivers have internal protection, self-resetting. Heatsink temperature monitored and input is muted if safe temperature is exceeded, self-resetting. Transformer has internal thermal fuse, self-resetting.

Transducers

<i>Low-Frequency Transducer</i>	
Diameter	15" (381mm)
Voice Coil Diameter	3" (76.2mm)
Power Handling	400 watts RMS
<i>Mid-Frequency Transducer</i>	
Diameter	10" (254mm)
Voice Coil Diameter	2.5" (63.5mm)
Power Handling	300 watts RMS
<i>High-Frequency Transducer</i>	
Diaphragm Diameter	2" (51mm)
Voice Coil Diameter	2" (51mm)
Throat Size	1" (25.4mm)
Power Handling	80 watts RMS
Diaphragm Material	Titanium

Power Amplifiers

<i>Low-Frequency Amplifier</i>	
Power Output	550 watts RMS
THD	<0.05% typical
<i>Mid-Frequency Amplifier</i>	
Power Output	350 watts RMS
THD	<0.05% typical
<i>High-Frequency Amplifier</i>	
Power Output	100 watts RMS
THD	<0.02% typical

Line Input Power

Voltage	117Vac, 60 Hz
Current	6.9 amps
Power	800 watts

Physical

Height	19.75"
Width	30.54"
Depth	19.5"
Weight	120 lbs.
Enclosure	18mm thick, 13 ply Baltic Birch plywood
Mounting Methods	3/8 eyebolt suspension

WARRANTY AND SERVICE

The unit, parts and workmanship are fully guaranteed to be free of defects under normal use and service for a period of three years from the date of purchase. The Internal Speakers that are used in this pro audio cabinet are fully guaranteed to be free of defects under normal use and service for a period of three years.

Any damage resulting from the misuse or the failure to follow the precautions and instructions will void the warranty.

In the event that the unit needs to be repaired, Please return the unit to ISP Technologies directly. Simply repack the unit, send a copy of the original receipt, a note stating the problem, and send it to:

ISP Technologies, LLC
5479 Perry Drive Suite B
Waterford, MI 48329
Attn: Repair Dept.

All shipping charges must be fully prepaid.

ISP will not be responsible for any damages incurred in shipping of any unit. Any claim will need to be settled with the shipping company.

The warranty will be voided if the serial number has been tampered with in any way.

NOTE: This Product may be covered under one or more of the following patents or patents pending: 7,035,413; 6,944,305; 6,931,134; 6,831,514; 6,091,013

Should you have any questions for the repair department prior to returning the product please call 1-(248)-673-7790

NOTE: If it is determined that the power amp module has failed, it is possible for an ISP certified service center to remove the module from the cabinet by removing the mounting screws and disconnecting the speaker terminals and the transformer. The module may be sent back to ISP separately. Please contact ISP for technical support to help determine if the amplifier module may be defective.



ISP TECHNOLOGIES, LLC
5479 Perry Drive Suite B
Waterford, MI. 48329
248-673-7790
FAX: 248-673-7696
www.isptechnologies.com